

A SELECTION FROM THE VAST RANGE OF

CLARKE®

QUALITY PRODUCTS

AIR COMPRESSORS
From DIY to industrial. Plus air tools, spray guns and accessories.

GENERATORS

Prime duty or emergency standby for business, home and leisure.

POWER WASHERS

Hot and cold, electric and engine driven - we have what you need.

WELDERS

Mig, Arc, Tig and Spot. From DIY to auto/industrial.

METALWORKING

Drills, grinders and saws for DIY and professional use.

WOODWORKING

Saws, sanders, lathe, mortisers and dust extraction.

HYDRAULICS

Cranes, body repair kits, transmission jacks for all types of workshop use.

WATER PUMPS

Submersible, electric and engine driven for DIY, agriculture and industry.

POWER TOOLS

Angle grinders, cordless drill sets, saws and sanders.

STARTER/CHARGERS

All sizes for car & commercial use.



CLARKE INTERNATIONAL

Hemmill Street, Epping, Essex, CM16 4LG, ENGLAND

Telephone: 01992 565333 Fax: 01992561562

e-mail: Parts@clarkeinternational.com Service@clarkeinternational.com

For spares and servicing, please contact your nearest dealer, or Clarke International on 020-8988-7400

CLARKE® WOODWORKER

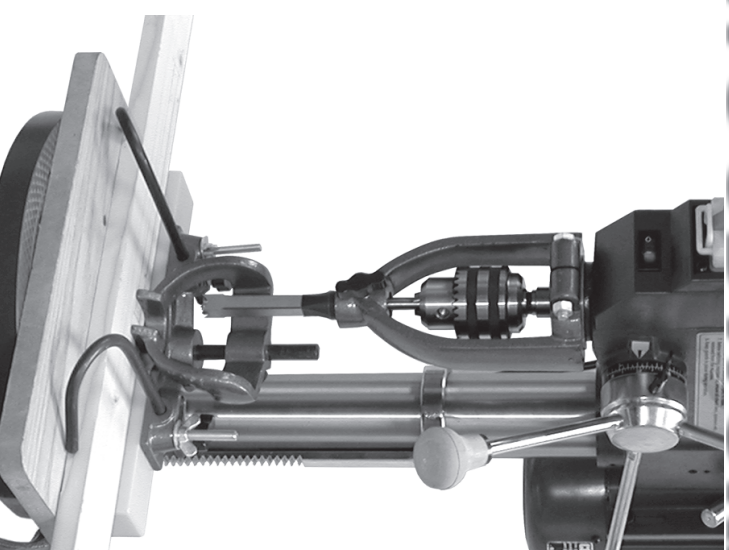

MORTISE ATTACHMENT

Model No. CMA 1B

Part No. 6500023

OPERATING & MAINTENANCE
INSTRUCTIONS



Thank you for selecting this CLARKE Bench Mortising Attachment.

This attachment is compatible with the following CLARKE Drill Presses.

CDP3201B • CDP251F • CDP301B • CDP351F

Before operating the machine, please read this leaflet thoroughly and follow the instructions carefully. In doing so you will ensure the safety of yourself and that of others around you, and you can look forward to the machine giving you long and satisfactory service.

GUARANTEE

This CLARKE product is guaranteed against faulty manufacture for a period of 12 months from the date of purchase. Please keep your receipt as proof of purchase.

This guarantee is invalid if the product is found to have been abused or tampered with in any way, or not used for the purpose for which it was intended.

Faulty goods should be returned to their place of purchase, no product can be returned to us without prior permission.

This guarantee does not effect your statutory rights.

SPECIFICATIONS

Chisel Collar Size 3/4"

Fence Size 40X350mm

Net Weight 24kg

REPLACEMENT PARTS

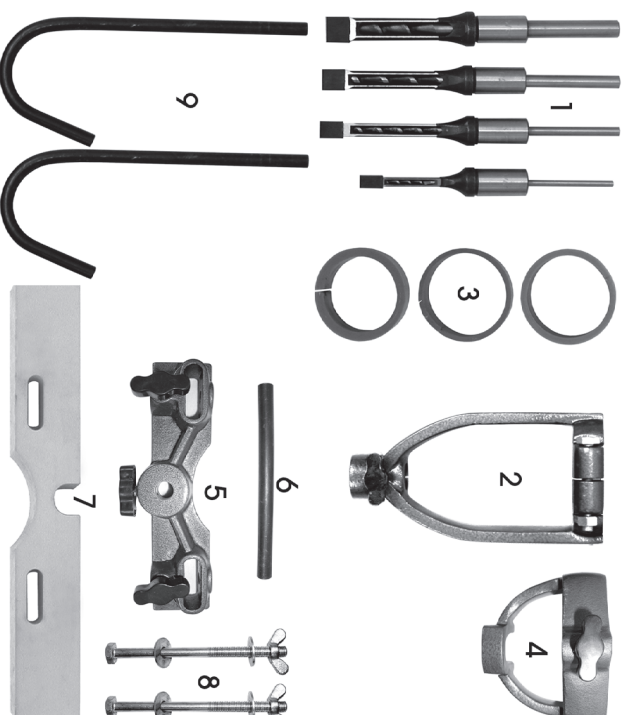

No. Description	Qty	Part No.	No. Description	Qty	Part No.
1 1/4" Chisel	1	6500025	4 Hold Down	1	EFCMA1B04
1 3/8" Chisel	1	6500026	5 Hold Down Support	1	EFCMA1B05
1 1/2" Chisel	1	6500027	6 Hold Down Post	1	EFCMA1B06
1 5/8" Chisel	1	6500028	7 Fence	1	EFCMA1B07
2 Chisel Holder	1	EFCMA1B02	8 Screw w/Wing Nut	2	Not Available
3 Reducing Collar (set)	1	EFCMA1B03	9 Hooks	2	EFCMA1B09

ACCESSORIES

The following Mortising Chisels and Bits are available from your CLARKE dealer.

Mortise Width	Bit Shank Size	Part No.
1. 6mm (1/4")	5mm	6500025
2. 9mm (3/8")	6mm	6500026
3. 13mm (1/2")	9mm	6500027
4. 16mm (5/8")	13mm	6500028

SHARPENING THE DRILL BIT & CHISEL

For best performance the chisel and bit need to be kept sharp. Blunt cutting edges will give untidy and inaccurate mortises, and can cause overheating and breaking of the chisel and bit.

Sharpen the bit by using a small smooth file, following the original shape of the bit. File the inside edge of the spur, the sides of the broad point, and the cutting edge inwards towards the flutes of the bit to restore sharpness. Do not file the outside edge of the spur as this will affect the diameter of the bit.

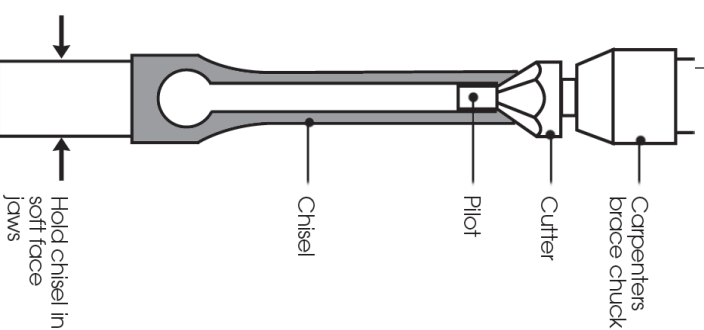
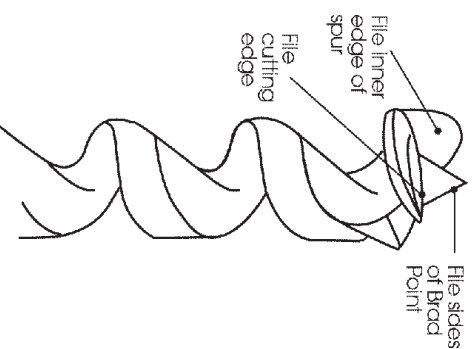

Use a Mortise chisel cutter with the correct size pilot to sharpen the chisel. Two or three turns of the cutter in a carpenters hand brace should be enough to sharpen the chisel. Remove any burrs from the outside of the chisel with a fine oilstone. Chisels and bits will need replacing when they become badly worn and difficult to sharpen.

-10-

SAFETY PRECAUTIONS

GENERAL SAFETY RULES FOR OPERATING MACHINERY

WARNING:

As with all machinery, there are certain hazards involved with their operation and use. Exercising respect and caution will considerably lessen the risk of personal injury. However, if normal safety precautions are overlooked or ignored, personal injury to the operator or damage to property, may result.

1. READ and BECOME FAMILIAR with the entire operating manual. Learn the machines' applications and limitations as well as the specific potential hazards peculiar to it.
2. EARTH ALL MACHINES. If the machine is equipped with three-pin plug, it should be plugged into a three-pin electrical socket. Never remove the earth pin.
3. ALWAYS ensure that ADEQUATE LIGHTING is available. A minimum intensity of 300 lux should be provided. Ensure that lighting is placed so that you will not be working in your own shadow.
4. CHECK for DAMAGE. Before using the machine, any damaged part, such as a guard etc., should be checked to ensure that it will operate properly, and perform its intended function. Check for alignment of moving parts, breakage of parts, mountings, and any other condition that may affect the machines' operation. Any damage should be properly repaired or the part replaced. If in doubt, DO NOT USE the machine. Consult your local dealer.
5. DISCONNECT the MACHINE from the power supply before servicing and when changing accessories or performing maintenance tasks.
6. KEEP GUARDS in place and in working order.
7. ALWAYS WEAR SAFETY GOGGLES, manufactured to the latest European Safety Standards. Also use face or dust mask if cutting operation is dusty. Everyday eyeglasses do not have impact resistant lenses, they are NOT safety glasses.
8. KEEP WORK AREA CLEAN. Cluttered areas and benches invite accidents.
9. DON'T FORCE the Machine. It will do a better and safer job at the rate for which it was designed.
10. REMOVE ADJUSTING KEYS AND WRENCHES. Form the habit of checking to see that keys and adjusting wrenches are removed from the machine before switching on.
11. DRUGS, ALCOHOL, MEDICATION. Do not operate machine whilst under the influence of drugs, alcohol or any medication.
12. USE RECOMMENDED ACCESSORIES. The use of improper accessories could be hazardous.
13. NEVER LEAVE MACHINE RUNNING UNATTENDED. Turn power OFF. Do not leave machine until it comes to a complete stop.

14. KEEP CHILDREN AWAY. All visitors should be kept a safe distance from the work area, especially whilst operating the unit.
15. MAINTAIN MACHINE IN TOP CONDITION. Keep tools sharp and clean for the best and safest performance. Follow maintenance instructions.
16. DON'T OVERREACH. Keep your proper footing and balance at all times. For best footing, wear rubber soled footwear. Keep floor clear of oil, scrap wood, etc.
17. WEAR PROPER APPAREL. Loose clothing or jewellery may get caught in moving parts. Wear protective hair covering to contain long hair.
18. BE AWARE that accidents are caused by carelessness due to familiarity. ALWAYS concentrate on the job in hand, no matter how trivial it may seem.

ADDITIONAL SAFETY INSTRUCTIONS when MORTISING

1. DO NOT USE until unit is completely assembled and installed according to these instructions.
2. IF YOU ARE NOT thoroughly familiar with the mortising operations, you should obtain advice from a qualified person.
4. NEVER TURN MACHINE ON before clearing the table of all objects (tools, scrap pieces, etc.).
5. ALWAYS KEEP hands, fingers and hair well away from the rotating bit.
6. DO NOT ATTEMPT to mortise materials that do not have a flat surface.
7. ALWAYS use the 'Hold Down' to prevent work from lifting when withdrawing the chisel.
8. ALWAYS SUPPORT workpiece securely against fence to prevent rotation.
9. ENSURE chisel and bit is sharp, undamaged and properly secured before use.
10. ENSURE the chuck key is removed before starting.
11. NEVER START the machine with the drill bit or chisel pressed against the workpiece.
12. NEVER PERFORM LAYOUT assembly or setup work on the machine with the cutting tool rotating.
13. ALWAYS ADJUST DEPTH STOP wherever possible, to avoid drilling into the table.
14. ALWAYS STOP the machine before removing scrap pieces from the table.
15. SHUT OFF POWER, remove the drill bit and chisel and clean the table before leaving the machine.
16. NEVER PLACE YOUR FINGERS in a position where the drill or cutting tool could contact them if the workplace should shift unexpectedly.

7

Observing all precautions (refer to your drill press manual), and ensuring there are no obstructions, or tools in the vicinity, plug into the mains supply and switch ON. Gently lower the chisel so that it contacts the work, and, ensuring it is properly positioned, proceed to force the chisel into the work.

If your drill press is provided with a depth stop, it may be used to limit the depth of the chisel cut. Refer to your drill press manual for the method of adjustment.

NOTES:

- *It is recommended that you check the position, and depth of cut, on a piece of scrap of similar size before cutting your workpiece.*
- *The rate of penetration of the chisel must be fast enough to prevent burning of the tip of the bit, but not so fast as to cause the machine to slow or stall. With experience you will find suitable feed rates to suit various types of timber.*
- *You may encounter smoke from the bit or material once the chisel has engaged the material. The smoke created is a natural operating occurrence in hollow chisel mortising and is caused by material chip friction and the resins in the stock being burned off. Bluing of the chisel after initial use is not indicative of a dull chisel, but a combination of friction and resin buildup on the cutting faces of the chisel.*
- *A dull chisel can be detected by the amount of excess force required to complete a cut.*
- *After the first cut, the workpiece must be moved along in the correct direction relative to the slot in the chisel, to allow chips to clear freely. Move the workpiece so that the chisel slot is releasing chips into the already cut part of the mortise.*
- *Do not have the slot against the blind end of the mortise, as the chips will not be able to clear from the chisel. This will cause overheating and possible breakage to the chisel or bit.*
- *When cutting deep mortises, make the cut in several stages of no more than 25mm each, to allow chips to clear.*
- *Always switch the mortising machine off after use. Never leave the machine running unattended.*
- *If the Mortising attachment is left on the drill press, ensure the plastic protection cap (provided), is placed over the end of the chisel to avoid the possibility of people damaging themselves on the sharp points subsequently.*

* Place the workpiece on to the table, up against the fence, then attach the two Hooks in the manner shown, pulling the workpiece up against the fence.

DO NOT force the workpiece, it should be firm, but allowed to move laterally, by hand.

- Lower the Hold Down so that it makes contact with the workpiece.

Again DO NOT force the hold down - the workpiece should be allowed to move laterally by hand.

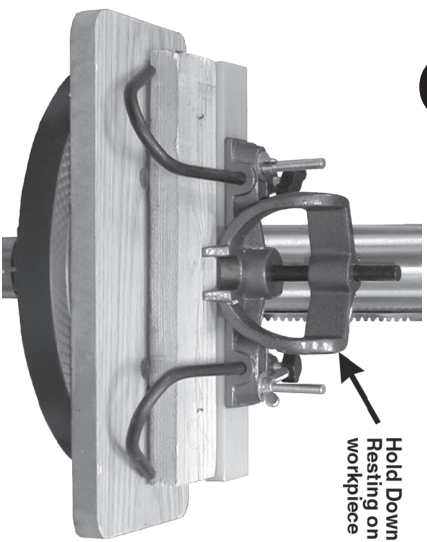

5

Lower the chisel and bit, (or raise the table) so it is directly above the proposed Mortise.

NOTE:

If your table is capable of rotating about the column, ensure it is secured with the hole in the table directly beneath the chisel.

If you have a round table with radial slots, which rotates about its axis, you need to lock the table in a position where the assembly can be manoeuvred, in the radial slots, so that the proposed Mortise lies directly beneath the chisel.

You should always mark your Mortise on the workpiece clearly, beforehand.

The chisel must be square with the workpiece, as shown. Move the complete assembly on the table until you are satisfied it is, then clamp the complete assembly to the table using the wing nuts on the hold down support securing bolts.

Your Morticing Attachment is now set up and ready for use.

6

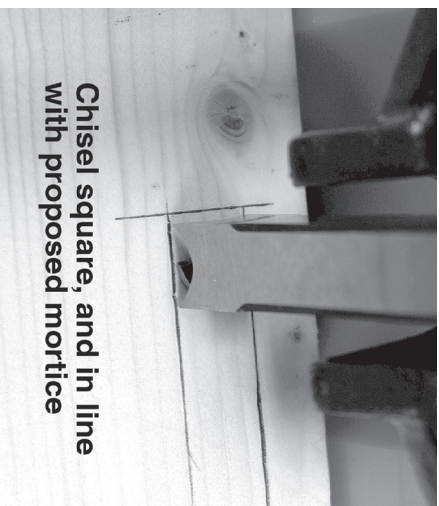

UNPACKING

Unpack the shipping carton, and lay out the components so that they can be clearly identified. Check them off as follows:

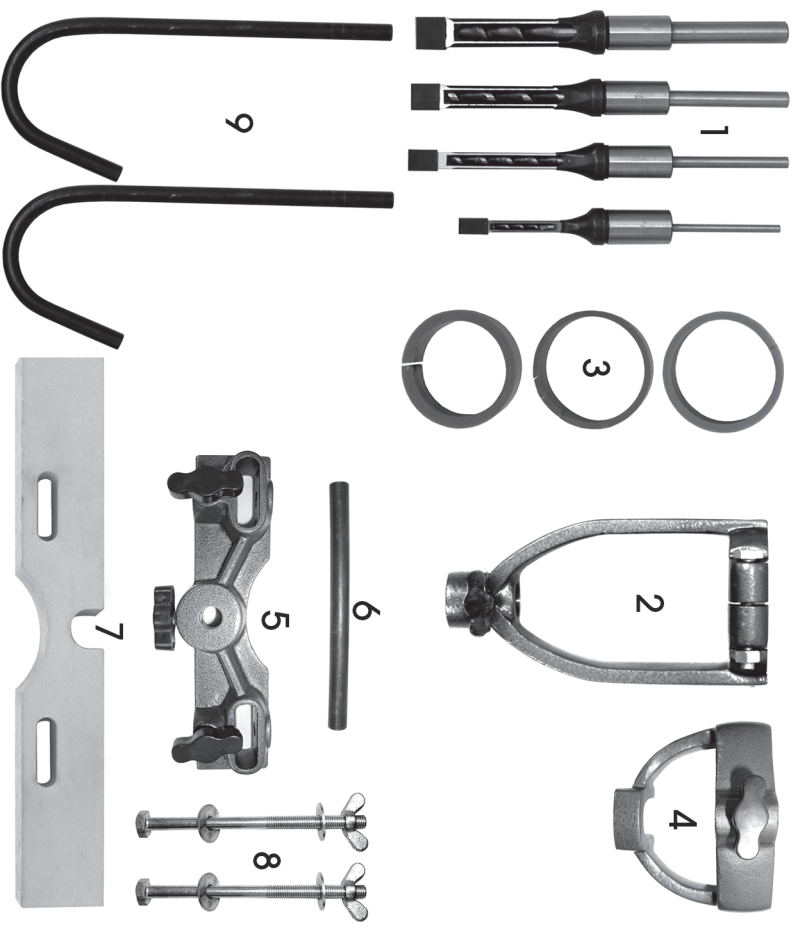

Should there be any deficiency or damage to any of the components, please contact your Clarke dealer immediately

- | | |
|---|--|
| 1. Chisel Sets -4 off (see Accessories) | 6. Hold Down Post |
| 2. Chisel Holder | 7. Fence |
| 3. Chisel Holder Collars Hold Down | 8. Mounting Bolts w/Wing Nuts and 2 x Flat Washers - 2 off |
| 4. Hold Down | 9. Workpiece Securing Hooks - 2 off |
| 5. Hold Down Support | |

INSTALLATION

WARNING: For your own safety, do not connect the Drill Press to a power source until the Mortising Attachment is fully assembled, and you have read and understood all safety and operational instructions.

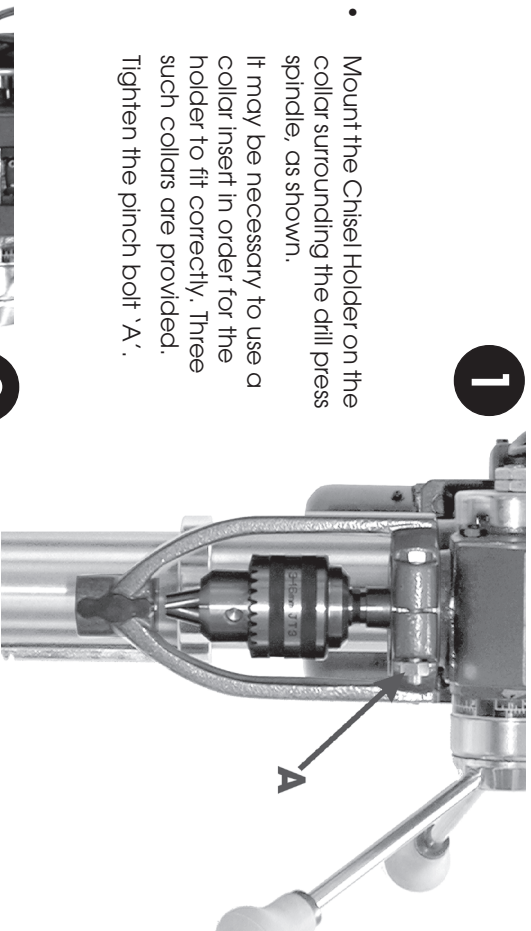

- Mount the Chisel Holder on the collar surrounding the drill press spindle, as shown.

It may be necessary to use a collar insert in order for the holder to fit correctly. Three such collars are provided. Tighten the pinch bolt 'A'.

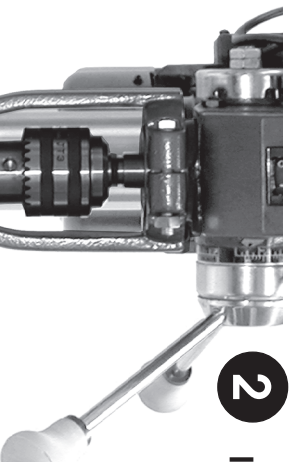

2

Install the chisel and bit as follows:

WARNING! Take great care when handling the chisel and bit...the edges are extremely sharp. Use the plastic protection cap (provided), whenever possible

- Separate the chisel and bit, then insert the chisel up through the hole in the Chisel Holder.
- Push the chisel up as far as possible into the holder, and nip up the securing screw to temporarily hold it in this position.

NOTE:

The opening in the side of the chisel should always be to the right or left, never to the front or rear. The opening allows chips to escape during operation. See 'Adjusting Chisel Parallel to Workpiece' on page 10.

- Push the bit up through the chisel, and into the opened jaws of the chuck.

IMPORTANT!

A clearance of 1/16" (1.5mm) MUST exist between the mating faces of the chisel and bit, as shown in Fig. 2A.

If the bit bottoms out in the chuck before it makes contact with the chisel, either grind off the end of the bit (shank), or, slacken the screw securing the chisel holder and lower the holder sufficiently so that a correct clearance may be set.

It should also be noted that it may be necessary to increase the size of the gap with hardwoods, or when cutting deep mortises.

Fig. 2A

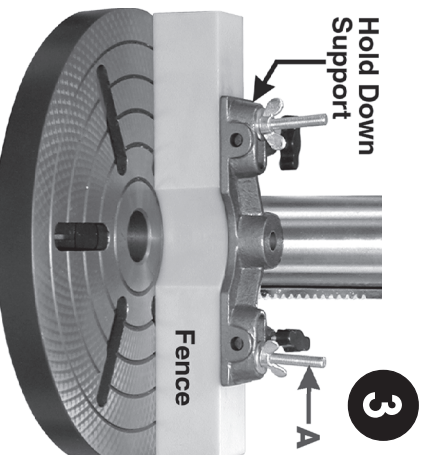
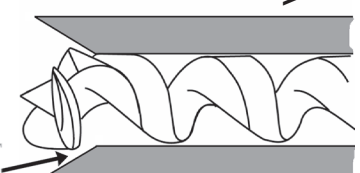

3

Hold Down Support

Fence

Attach the Fence and the Hold Down Support to the table in the manner shown. Do not fully tighten the wing nuts at this stage

Note that the securing bolts (A) are extra long. This is to allow a piece of timber to be placed beneath the fence, which may be used as a bed, on which to place the workpiece. This is used when through mortises are to be cut, and will avoid splintering of the workpiece and possible damage to the chisel and bit on breakthrough (Depending upon the type of table being used). Such a setup is shown in '4' below.

4

Piece of wood used when cutting through

Hold Down

Post

Insert the Hold Down Post into the hole in the hold down support, and secure, then slide the Hold Down on to it, securing it temporarily with the securing knob.

